

Vane pumps type PV serve to generate an oil flow in hydraulic systems.

ADVANTAGES

- easy commissioning by automatic air bleeding
- low noise level
- hydrodynamically lubricated bearings for long bearing life
- good sliding characteristics of control discs due to bronze coating and semi-fluid friction.

DESCRIPTION OF OPERATION

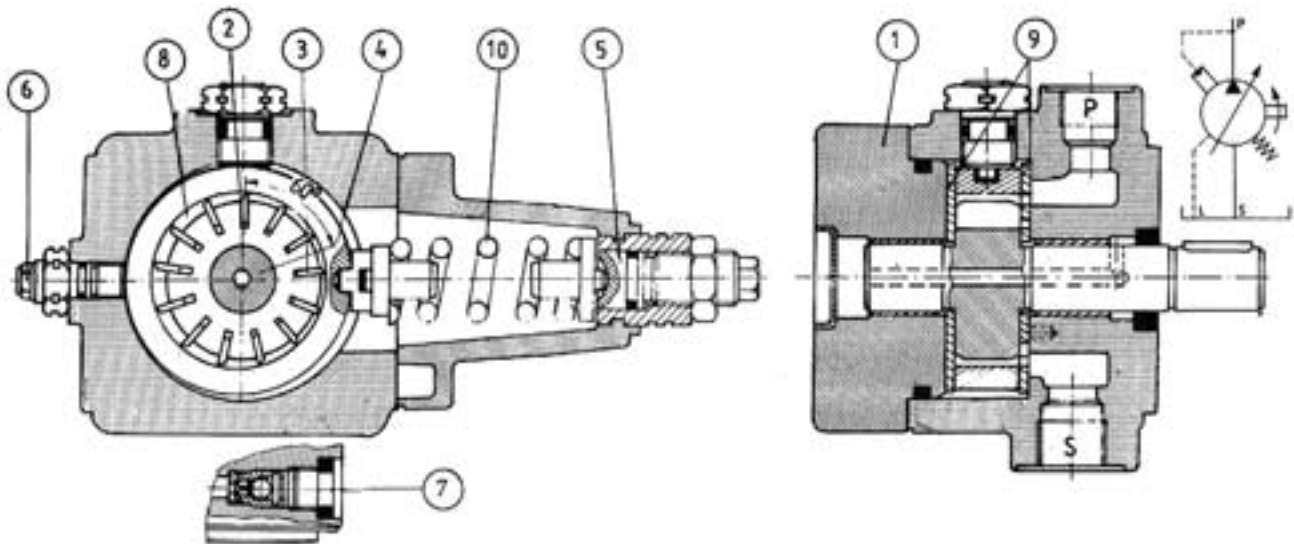

Hydraulic pumps type V3 are vane pumps with variable displacement and pressure control. Pumps type V3/12 are composed of a housing 1, rotor 2 with simple vanes 3, stator 4, pressure regulator 5, volume screw 6, valve for automatic air bleed 7 and control discs 9.

Suction and delivery

Two vanes 3, the rotor 2, the stator 4 and the discs 9 form the chambers for the transport of the fluid. By moving the rotor 2 to the right the chambers 8 increase, starting from the suction channel and they fill up with fluid. When these chambers have reached their maximum volume they are separated from the suction side by means of the control discs. When the rotor further turns to the right the chambers are connected to the pressure side.

They decrease their volume and thus fluid is pushed to the pressure channel P and into the system. Volume setting screw 6 is designed for limiting the maximum flow of the pump.

Pressure setting

The circular stator ring is kept in an eccentric position by means of the spring 10. Maximum working pressure required in the system is adjusted by the spring 10. On reaching the set pressure the stator 4 (overcoming resistance of the spring 10) moves out of its eccentric position. The eccentricity decreases till the minimum flow replacing the leakage oil is obtained. After a pressure drop in the system the stator 4 returns to the eccentric position and the pump delivers the full value of the set output flow.

Installation

Vane pumps type V3 can be installed in any desired position.

The pump may be connected to hydraulic systems only by means of flexible lines.

Drive

The pump may be connected to motor only by means of a flexible

coupling. All the coaxial conditions formulated by the coupling manufacturer must be maintained.

The shaft ends of both pump and motor may not transmit any longitudinal or radial forces.

Oil tank

The tank capacity must be properly selected so that the working temperature of oil do not exceed recommendations. If that is impossible a cooler must be installed.

Pipelines

The suction line should be designed so that the values of inlet pressure are not exceeded. The leakage lines should be fitted minimum 100 mm above the suction line and should be formed so that the leakages do not get immediately sucked back into the pump.

The suction lines and the leakage lines should be at least 200 mm apart. The pipe ends should be cut at a 45° angle and should not reach within 50 mm of the tank bottom.

All pipelines even at the minimum oil level in the tank must be dipped minimum 50 mm in order to avoid the build-up of foam.

TECHNICAL DATA

Hydraulic fluid		Mineral oil, phosphate ester
Nominal output flow Nominal output flow	Nominal output dm ³ / min	13 at n = 1450 min ⁻¹ p = 1 MPa
Inlet pressure	MPa	- 0,02 to + 0,5
Outlet pressure	MPa	max. 10
Leakage pressure	MPa	max. 0,2
Torque (drive shaft)	Nm	max 54
Revolution per minute	min ⁻¹	1000 do 1800
Nominal viscosity range - at pzero stroke < 6.3 MPa - at pzero stroke > 6.3 MPa	mm ² / s mm ² / s	16 to 160 25 to 160
Working temperature (fluid in a tank)	K	313 - 328
Fluid temperature range	K	263 - 343
Filtration	µm	16 (recommended 10 for long working life)
Pressure range related to spring force	MPa	C 25 from 1,2 to 2,5 C 40 from 2,0 to 4,0 C 63 from 3,0 to 6,3 C100 from 5,0 to 10,0
Mounting method		flange mounting
Direction		right
Pipe connections Pipe connections		threaded connections
Shaft loading		radial or axial loads can not be transferred
Weight	kg	6,25

OVERALL AND MOUNTING DIMENSIONS

Pump for flange mounting - overall dimensions in mm

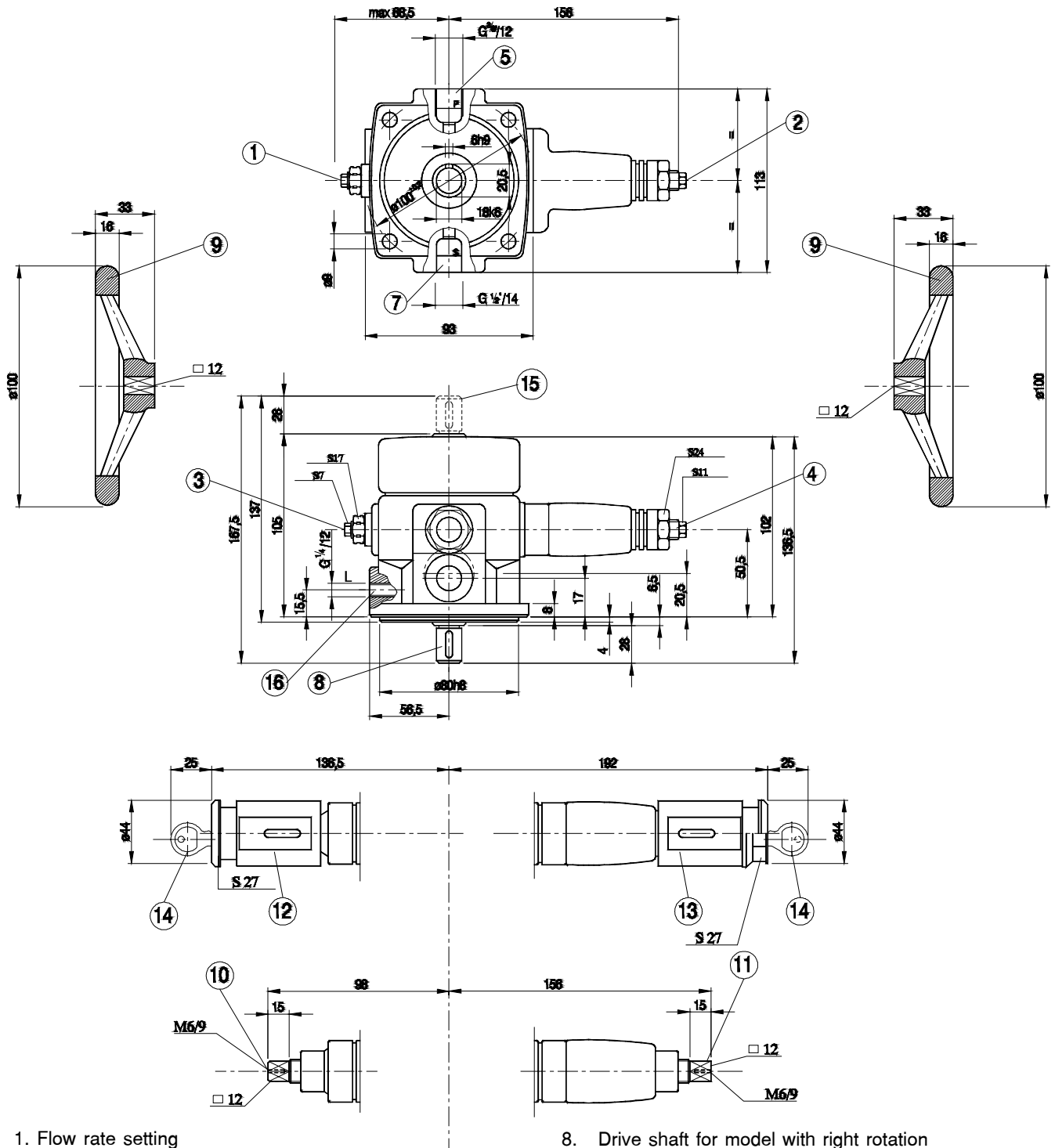

- | | |
|--|--|
| <ol style="list-style-type: none"> 1. Flow rate setting <ul style="list-style-type: none"> - rotation to the right decreases flow rate - rotation to the left increases flow rate 2. Pressure setting <ul style="list-style-type: none"> - rotation to the right increases operating pressure - rotation to the left decreases operating pressure 3. Flow rate setting (by means of screw A) 4. Pressure setting (by means of screw C) 5. Pressure port | <ol style="list-style-type: none"> 8. Drive shaft for model with right rotation 9. Accessories (against special order and agreed with the manufacturer). Setting by means of hand wheel fitted on square end setting 10. Flow rate setting by means of external square end (H) 11. Pressure setting by means of external square end (H) 12. Flow rate setting locked by key (S) 13. Pressure setting locked by key (S) 14. Key length 43 mm 15. 2-nd shaft end |
|--|--|

PERFORMANCE CURVES : measured at $v = 41 \text{ mm}^2/\text{s}$ and $T = 323 \text{ K}$ and $n = 1450 \text{ min}^{-1}$

Flow - operating pressure - drive power curves for delivering and zero stroke.

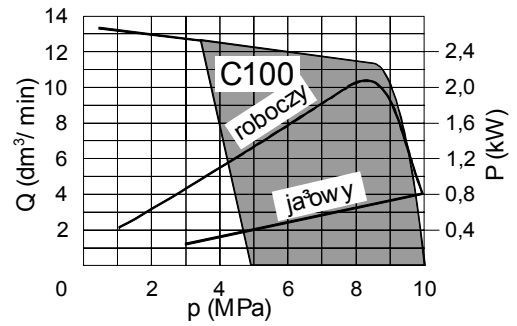
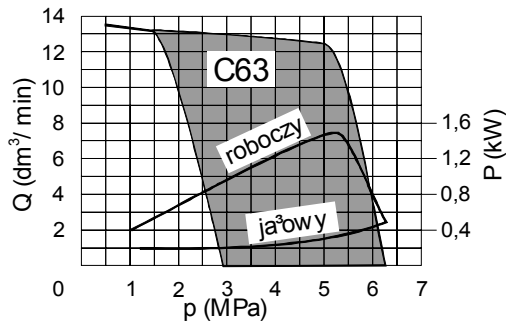
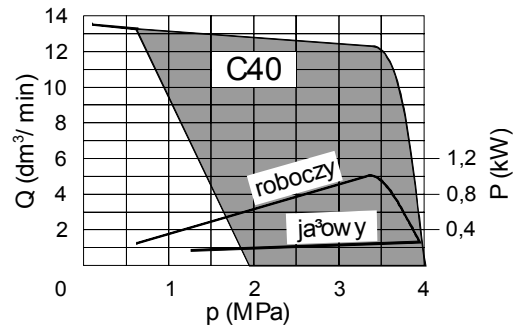
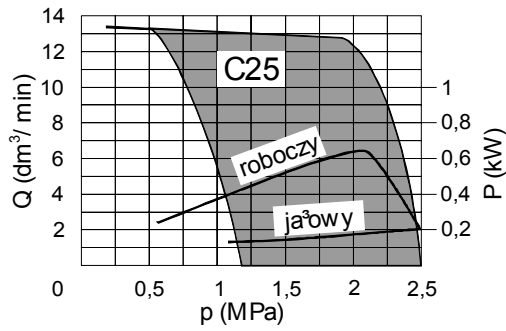

Leakage - operating pressure curve

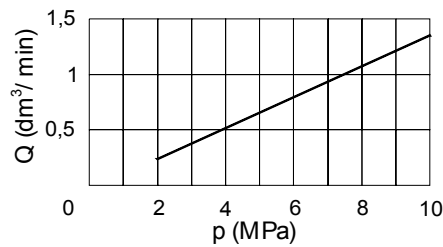

Noise level - operating pressure curves at zero stroke and delivering, measured at distance of 1 m from pump

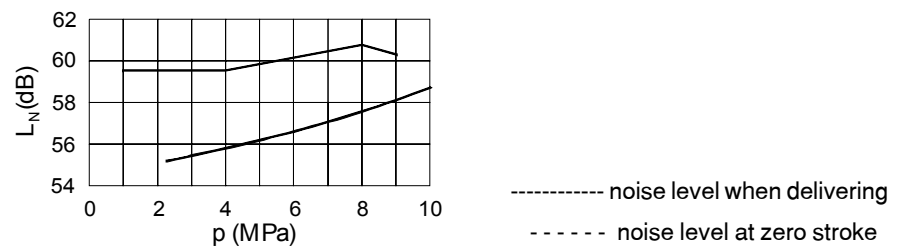

OVERALL AND CONNECTION DIMENSIONS FOR BRACKETS

Single - flange bracket - overall dimensions in mm

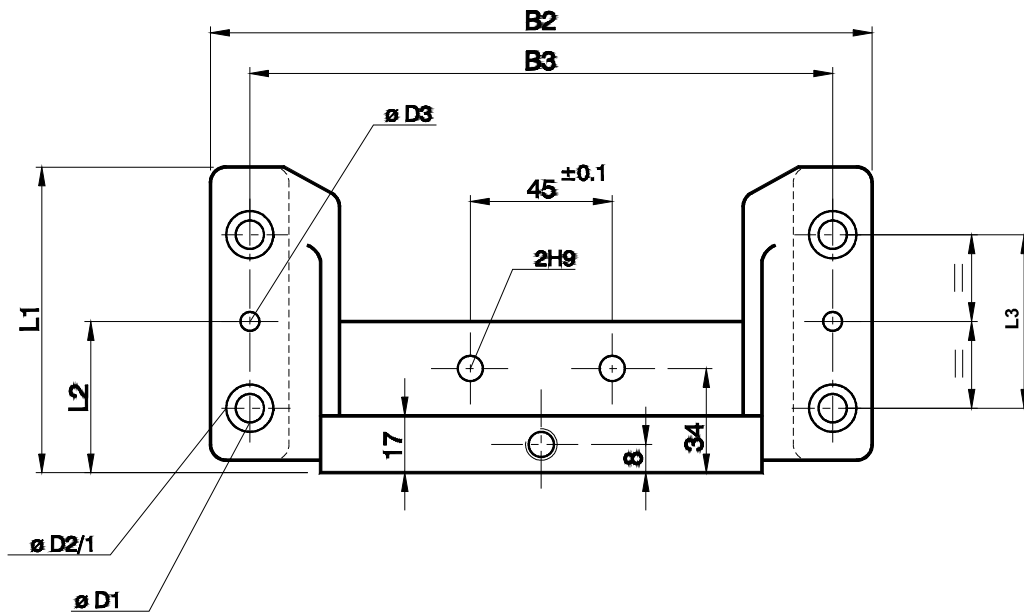
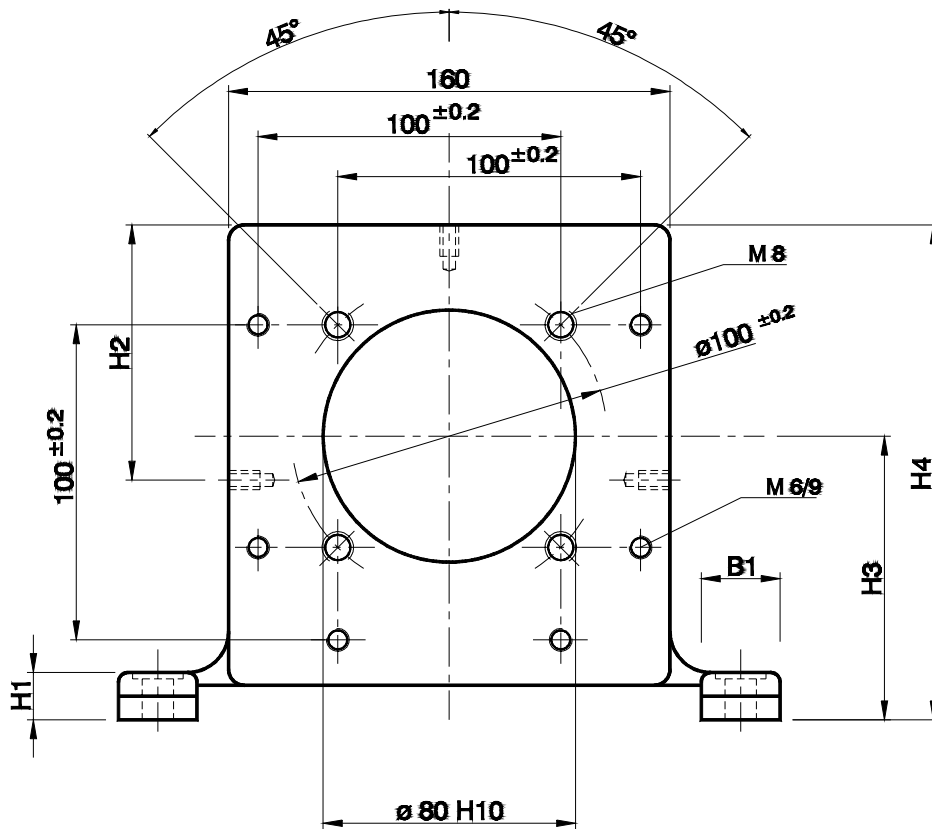

Drive power in kW	B1	B2	B3 ±0.2	D1	D2	D3±0.1	H1	H2±0.2	H3±0.1	H4	L1	L2±0.2	L3±0.2	Weight
1,1 ... 1,5	35	210	185	9	15	6	15	80	90	157	93	48	55	2,5 kg
2,2 ... 3	35	210	185	9	15	6	25	80	100	167	93	48	55	3,7 kg
4	35	210	185	9	15	6	37	80	112	179	93	48	55	4 kg

Two - flange bracket - overall dimensions in mm

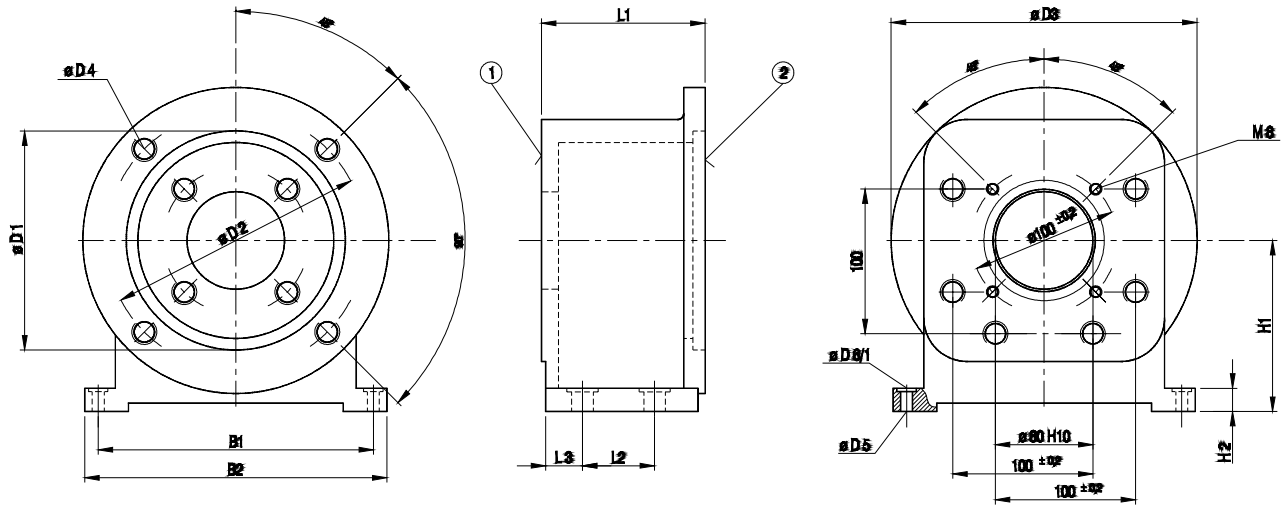

Power drive in kW	B1±0.2	B2	D1 ^{H10}	D2±0.2	D3	D4	D5	D6	H1±0.2	H2	L1±0.2	L2	L3	Weight
0,55 ... 1,5	180	210	130	165	200	M10	11	18	112	15	102	60	15	3,5 kg
2,2 ... 4	220	250	180	215	250	M12	14	20	132	15	112	60	20	4 kg

1 - Pump flange

2 - Motor flange

Note : Bracket and hand wheel available on a special order to be agreed with the manufacturer.

HOW TO ORDER

Orders coded in the way showed below should be forwarded to the manufacturer.

1 PV2V3	/12	1							
---------	-----	---	--	--	--	--	--	--	--

Series number:
 31 = 31
 (30 - 39) - Installation and connection dimensions unchanged

Nominal output flow - size 12 = 12
 8.5 cm³/rev

Rotation direction :
 Right = R
 Model with double shaft = D

Threaded connections = 1

Sealing
 For fluids on mineral oil base = M
 For fluids on phosphate ester base = V

Pressure setting
 With hexagon end screw = C
 With square end screw = H
 Lockable pressure regulator = S

Zero stroke pressure range
 10 MPa zero stroke pressure = 100
 6.3 MPa zero stroke pressure = 63
 4.0 MPa zero stroke pressure = 40
 2.5 MPa zero stroke pressure = 25

Flow setting
 With hexagon end screw = A
 With square end screw = H
 Lockable flow regulator = S

Air bleed valve

Additional requirements in clear text (to be agreed with the manufacturer)

Coding example : 1PV2V3-31/12 R1MC100A1

PONAR WADOWICE S.A.
ul. Wojska Polskiego 29
34-100 Wadowice
tel. 033/ 823 39 43, 823 30 41
fax 033/ 873 48 80
e-mail: ponar@ponar-wadowice.pl

